

ASSURING THE PROMISE OF 5G

Experience from Test, Trials & Deployments
5G Test & Measurement Equipment

Manoharan C P
Director – Sales Development, INDIA and SEA

Global
Customers

1,500

Spirent
Employees

1,444

Countries Served

50

Market Cap
(Sept 5 2018)

\$990 M

Exchange

LSE

Symbol

SPT.L

Sales (2017)

\$455 M

R&D Investment (2017)

\$103 M

Different Challenges in 5G Rollout...



Market Acceleration

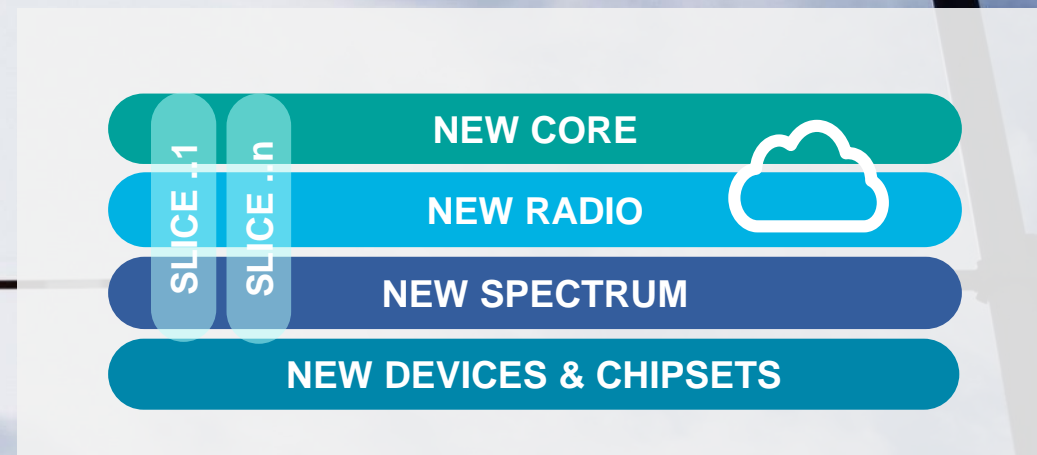

New Complexity



All Things to All Users



New Security Challenges

Where best to focus....

Simplify 5G



OTA & Conducted
New test techniques | Reduced test variants & costs

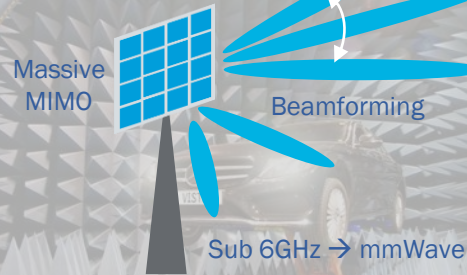

5G Radio

Accelerate 5G

Core Network Evolution

NR | Scale | Edge | Slicing

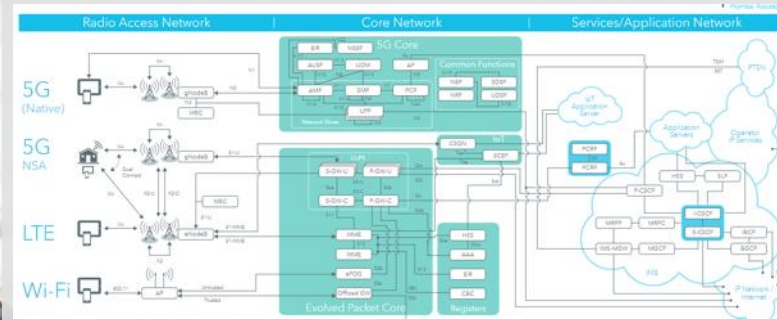

5G Core

Assure 5G ✓

Perceived User Experience

Throughput | Latency | vMOS

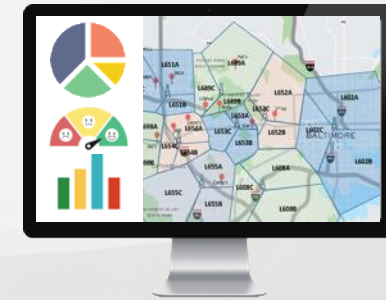

5G User Experience

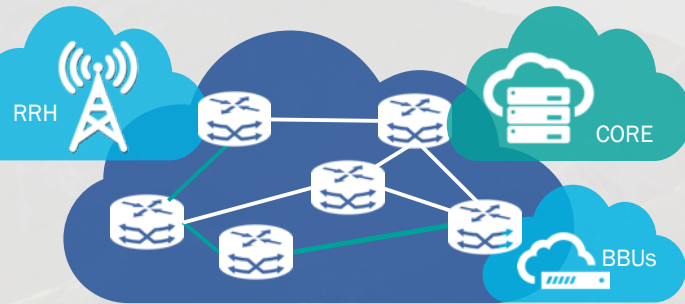

Multi-Speed Ethernet Connectivity
10 to 400G

5G Front & Backhaul

Multi-Vendor

Virtual Infrastructure | Service Chains | Lifecycle Management

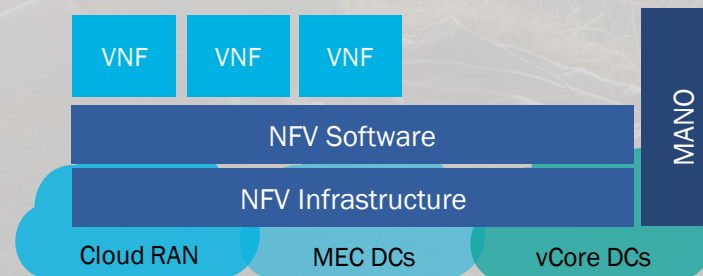

5G NFVi



Performance

Location Accuracy | Handover | Audio & Video Quality

5G Devices

5G exacerbates Security risks

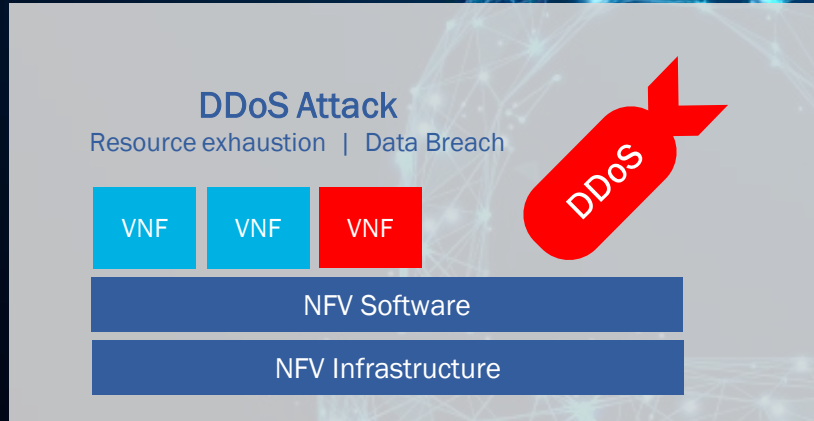

NFVi Attacks

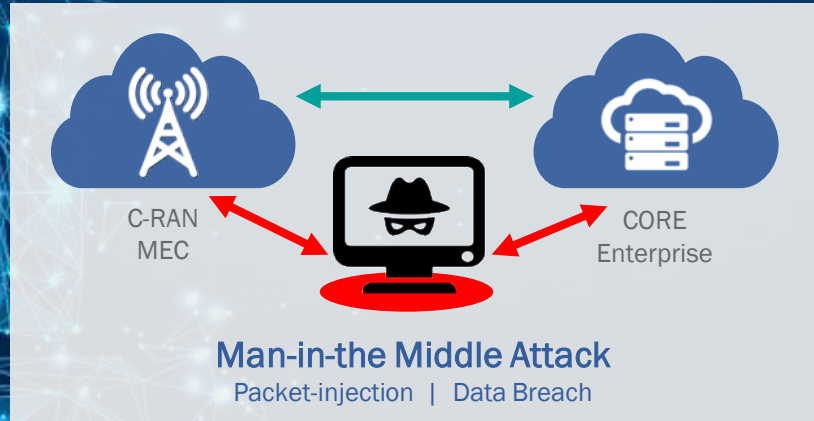

Edge Distribution Attacks

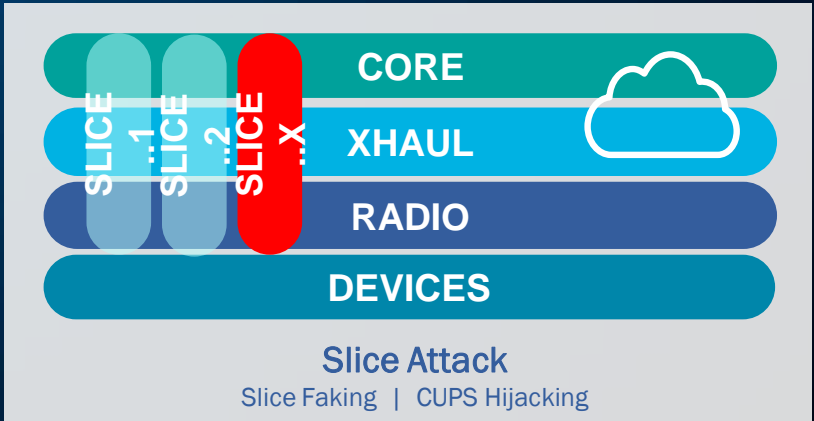

Network Slice Attacks



IoT Attacks

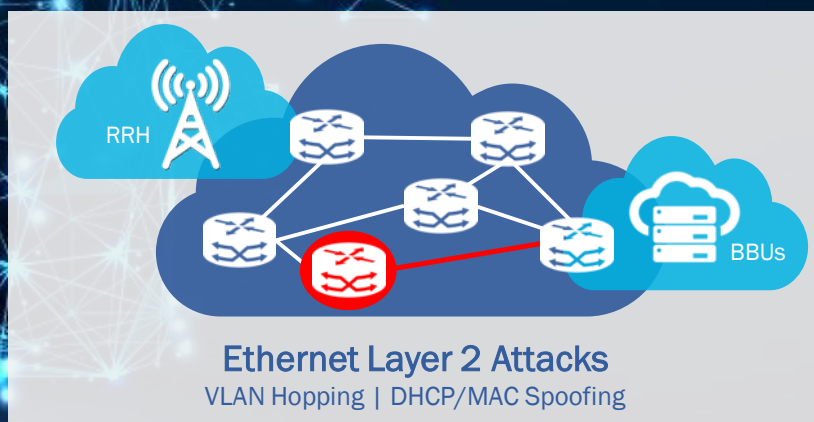

Ethernet Fronthaul Attacks



Security Gateway Attacks

Automate to Accelerate

Lab & Test Automation

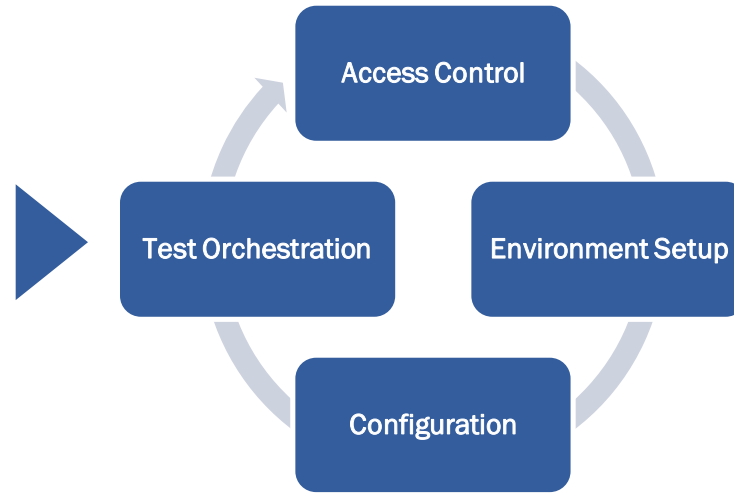

Automation of 5G labs

- Accelerates 5G product lifecycle
- Reduces costs
- Maximizes resource utilization
- Reduces setup times
- Increases collaboration

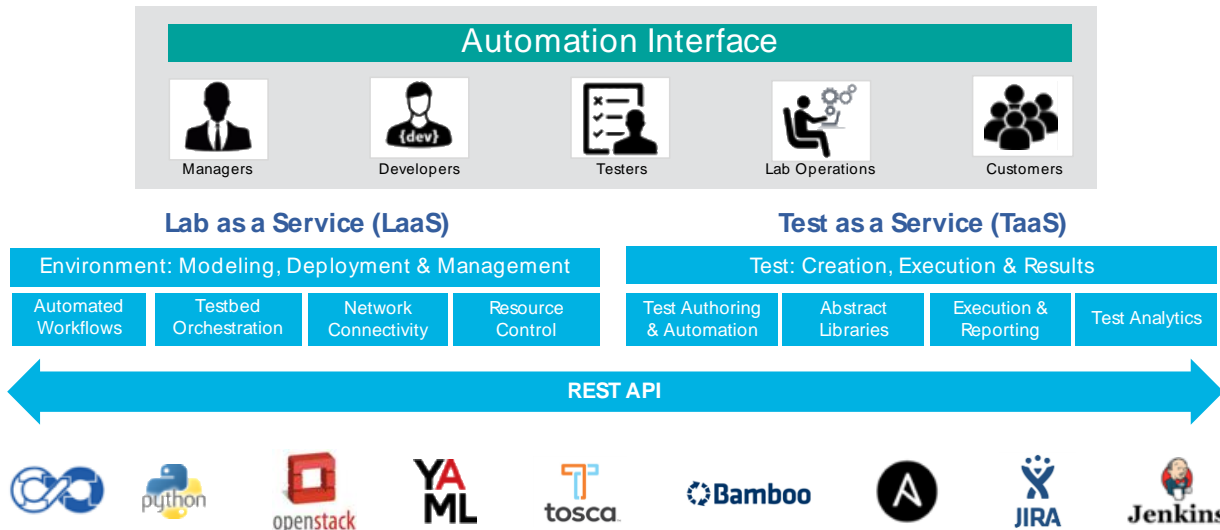

Spirent 5G Portfolio

5G Devices	5G New Radio	5G Fronthaul	5G C-RAN	5G Backhaul	5G Core
Velocity & iTest – 5G Lab & Test Automation with DevOps Continuous Testing					
Vertex – 5G New Radio RF Channel Emulation	<input checked="" type="checkbox"/> STC – 5G NG FHaul validation		<input checked="" type="checkbox"/> Spirent TestCenter – 5G Cloud RAN & Distributed Data Center validation		
<input checked="" type="checkbox"/> 8100 – 5G device perf. testing				<input checked="" type="checkbox"/> Landslide – 5G Core Network Evolution emulation, test & validation	
<input checked="" type="checkbox"/> UMETRIX – 5G user experience evaluation				<input checked="" type="checkbox"/> VisionWorks – 5G Lifecycle Service Assurance with Active Test & Intelligent Automation	
<input checked="" type="checkbox"/> GNSS 63x/7x – Positioning perf.				<input checked="" type="checkbox"/> Spirent Security Labs - 5G Cybersecurity testing & auditing	

Spirent's Service Delivery



- Distributed Secure Converged Core - Network Slicing end-to-end including the Edge Cloud
- Automated Infra/Network/App/Services Management of NFV through integrated MANO & SDN
- Support of DevOps /Micro Services/Cloud Native to achieve Agility for Faster Service Delivery
- Zero-Touch turn-up/turn-down of NFV Cloud Life Cycle Management.

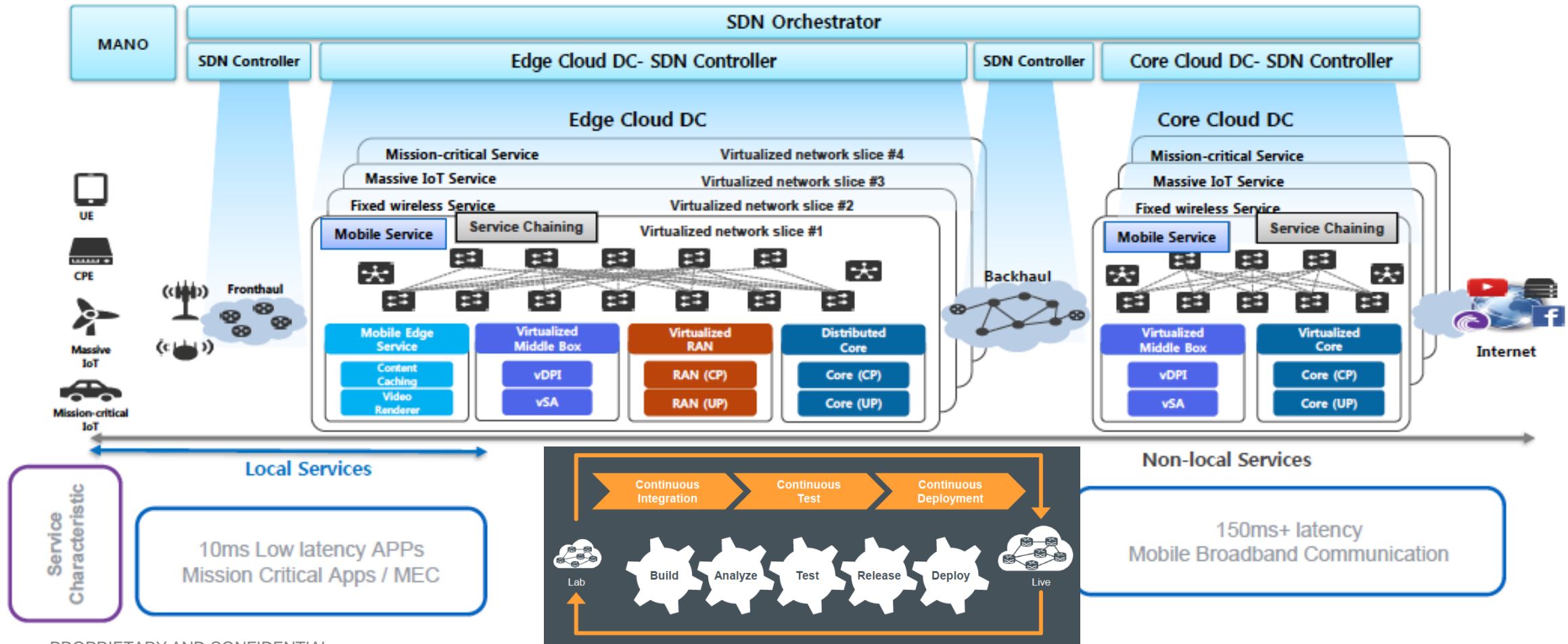

Best 5G User Experience

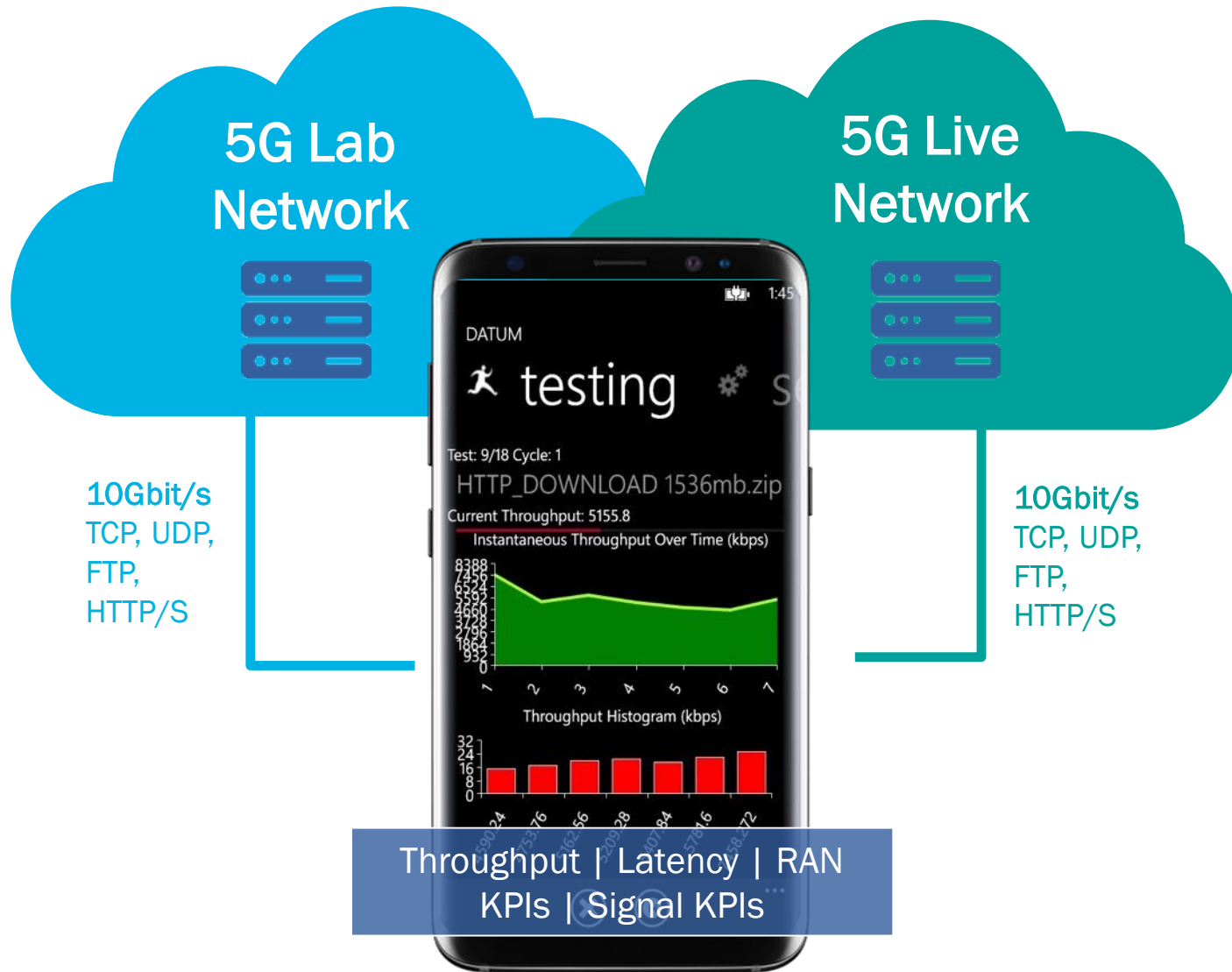

Measure what matters the most



the User Experience

5G Consumer Survey (Qualcomm):

85% want faster connectivity

48% want lightning fast browsing

37% want to download content 10x faster

27% want better quality video calls

Our Customers

Develop

Operate

Wireless & Positioning Device Manufacturers



Network Equipment Manufacturers



Network Operators



Enterprises & Governments





Spirent® Communications, Inc. and its related company names, branding, product names and logos referenced herein, and more specifically “Spirent” are either registered trademarks or pending registration within relevant national laws.